



**COMMONWEALTH OF PENNSYLVANIA  
DEPARTMENT OF ENVIRONMENTAL PROTECTION  
AIR QUALITY PROGRAM**

**STATE ONLY NATURAL MINOR OPERATING PERMIT**

Issue Date: May 28, 2021

Effective Date: June 11, 2021

Expiration Date: May 28, 2026

In accordance with the provisions of the Air Pollution Control Act, the Act of January 8, 1960, P.L. 2119, as amended, and 25 Pa. Code Chapter 127, the Owner, [and Operator if noted] (hereinafter referred to as permittee) identified below is authorized by the Department of Environmental Protection (Department) to operate the air emission source(s) more fully described in this permit. This Facility is subject to all terms and conditions specified in this permit. Nothing in this permit relieves the permittee from its obligations to comply with all applicable Federal, State and Local laws and regulations.

The regulatory or statutory authority for each permit condition is set forth in brackets. All terms and conditions in this permit are federally enforceable unless otherwise designated.

**State Only Permit No: 56-00025**

Federal Tax Id - Plant Code: 23-1374051-17

**Owner Information**

Name: NEW ENTERPRISE STONE & LIME CO INC  
Mailing Address: PO BOX 77  
NEW ENTERPRISE, PA 16664-0077

**Plant Information**

Plant: NEW ENTERPRISE STONE/BAKERSVILLE QUARRY  
Location: 56 Somerset County 56921 Jefferson Township  
SIC Code: 1422 Mining - Crushed And Broken Limestone

**Responsible Official**

Name: PAUL I DETWILER  
Title: PRES  
Phone: (814) 766 - 2211 Email:

**Permit Contact Person**

Name: CAROLYN SPEICHER  
Title: ENVIRONMENTAL MGR  
Phone: (814) 766 - 2211 Email: CSpeicher@nesl.com

[Signature] \_\_\_\_\_

MARK R. GOROG, P.E., ENVIRONMENTAL PROGRAM MANAGER, SOUTHWEST REGION



## SECTION A. Table of Contents

### Section A. Facility/Source Identification

Table of Contents  
Site Inventory List

### Section B. General State Only Requirements

- #001 Definitions.
- #002 Operating Permit Duration.
- #003 Permit Renewal.
- #004 Operating Permit Fees under Subchapter I.
- #005 Transfer of Operating Permits.
- #006 Inspection and Entry.
- #007 Compliance Requirements.
- #008 Need to Halt or Reduce Activity Not a Defense.
- #009 Duty to Provide Information.
- #010 Revising an Operating Permit for Cause.
- #011 Operating Permit Modifications
- #012 Severability Clause.
- #013 De Minimis Emission Increases.
- #014 Operational Flexibility.
- #015 Reactivation
- #016 Health Risk-based Emission Standards and Operating Practice Requirements.
- #017 Circumvention.
- #018 Reporting Requirements.
- #019 Sampling, Testing and Monitoring Procedures.
- #020 Recordkeeping.
- #021 Property Rights.
- #022 Alternative Operating Scenarios.
- #023 Reporting
- #024 Report Format

### Section C. Site Level State Only Requirements

- C-I: Restrictions
- C-II: Testing Requirements
- C-III: Monitoring Requirements
- C-IV: Recordkeeping Requirements
- C-V: Reporting Requirements
- C-VI: Work Practice Standards
- C-VII: Additional Requirements
- C-VIII: Compliance Certification
- C-IX: Compliance Schedule

### Section D. Source Level State Only Requirements

- D-I: Restrictions
- D-II: Testing Requirements
- D-III: Monitoring Requirements
- D-IV: Recordkeeping Requirements
- D-V: Reporting Requirements
- D-VI: Work Practice Standards
- D-VII: Additional Requirements

Note: These same sub-sections are repeated for each source!

### Section E. Source Group Restrictions

- E-I: Restrictions



## SECTION A. Table of Contents

- E-II: Testing Requirements
- E-III: Monitoring Requirements
- E-IV: Recordkeeping Requirements
- E-V: Reporting Requirements
- E-VI: Work Practice Standards
- E-VII: Additional Requirements

### Section F. Alternative Operating Scenario(s)

- F-I: Restrictions
- F-II: Testing Requirements
- F-III: Monitoring Requirements
- F-IV: Recordkeeping Requirements
- F-V: Reporting Requirements
- F-VI: Work Practice Standards
- F-VII: Additional Requirements

### Section G. Emission Restriction Summary

### Section H. Miscellaneous

**SECTION A. Site Inventory List**

Source ID	Source Name	Capacity/Throughput	Fuel/Material
108	CRUSHING/SCREENING PLANT	1,500.000 Tons/HR	LIMESTONE
201	HAUL ROADS	N/A	
C03	THREE (3) WATER SPRAY SYSTEMS		
C04	NESCO WATER SPRAY SYSTEM #1		
C05	NESCO WATER SPRAY SYSTEM #2		
C06	WATER SPRAY SYSTEM		
C108A	AEROPULSE (PR225-12) BAGHOUSE		
C108B	AEROPULSE (PR225-10) BAGHOUSE		
C201	TWO (2) WATER TRUCKS		
S108A	BAGHOUSE (PR225-12) STACK		
S108B	BAGHOUSE (PR225-10) STACK		
Z108	CRUSHING/SCREENING FUGITIVES		
Z201	HAUL ROAD FUGITIVE EMISSIONS		

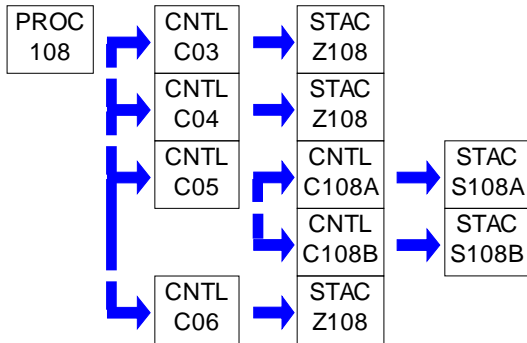
**PERMIT MAPS**

**SECTION B. General State Only Requirements****#001 [25 Pa. Code § 121.1]****Definitions.**

Words and terms that are not otherwise defined in this permit shall have the meanings set forth in Section 3 of the Air Pollution Control Act (35 P.S. § 4003) and in 25 Pa. Code § 121.1.

**#002 [25 Pa. Code § 127.446]****Operating Permit Duration.**

- (a) This operating permit is issued for a fixed term of five (5) years and shall expire on the date specified on Page 1 of this permit.
- (b) The terms and conditions of the expired permit shall automatically continue pending issuance of a new operating permit, provided the permittee has submitted a timely and complete application and paid applicable fees required under 25 Pa. Code Chapter 127, Subchapter I and the Department is unable, through no fault of the permittee, to issue or deny a new permit before the expiration of the previous permit.

**#003 [25 Pa. Code §§ 127.412, 127.413, 127.414, 127.446 & 127.703(b)]****Permit Renewal.**

- (a) The permittee shall submit a timely and complete application for renewal of the operating permit to the appropriate Regional Air Program Manager. The application for renewal of the operating permit shall be submitted at least six (6) months and not more than 18 months before the expiration date of this permit.
- (b) The application for permit renewal shall include the current permit number, a description of any permit revisions that occurred during the permit term, and any applicable requirements that were promulgated and not incorporated into the permit during the permit term. An application is complete if it contains sufficient information to begin processing the application, has the applicable sections completed and has been signed by a responsible official.
- (c) The permittee shall submit with the renewal application a fee for the processing of the application as specified in 25 Pa. Code § 127.703(b). The fees shall be made payable to "The Commonwealth of Pennsylvania Clean Air Fund" and submitted with the fee form to the respective regional office.
- (d) The renewal application shall also include submission of proof that the local municipality and county, in which the facility is located, have been notified in accordance with 25 Pa. Code § 127.413.
- (e) The application for renewal of the operating permit shall also include submission of supplemental compliance review forms in accordance with the requirements of 25 Pa. Code § 127.412(b) and § 127.412(j).
- (f) The permittee, upon becoming aware that any relevant facts were omitted or incorrect information was submitted in the permit application, shall promptly submit such supplementary facts or corrected information as necessary to address any requirements that become applicable to the source after the permittee submits a complete application, but prior to the date the Department takes action on the permit application.

**#004 [25 Pa. Code § 127.703]****Operating Permit Fees under Subchapter I.**

- (a) The permittee shall pay the annual operating permit maintenance fee according to the following fee schedule in either paragraph (1) or (2) in accordance with 25 Pa. Code § 127.703(d) on or before December 31 of each year for the next calendar year.
- (1) For a synthetic minor facility, a fee equal to:
- (i) Four thousand dollars (\$4,000) for calendar years 2021—2025.
  - (ii) Five thousand dollars (\$5,000) for calendar years 2026—2030.
  - (iii) Six thousand three hundred dollars (\$6,300) for the calendar years beginning with 2031.

**SECTION B. General State Only Requirements**

(2) For a facility that is not a synthetic minor, a fee equal to:

- (i) Two thousand dollars (\$2,000) for calendar years 2021—2025.
- (ii) Two thousand five hundred dollars (\$2,500) for calendar years 2026—2030.
- (iii) Three thousand one hundred dollars (\$3,100) for the calendar years beginning with 2031.

(b) The applicable fees shall be made payable to "The Commonwealth of Pennsylvania Clean Air Fund" with the permit number clearly indicated and submitted to the respective regional office.

**#005 [25 Pa. Code §§ 127.450 (a)(4) and 127.464]****Transfer of Operating Permits.**

(a) This operating permit may not be transferred to another person, except in cases of transfer-of-ownership that are documented and approved by the Department.

(b) In accordance with 25 Pa. Code § 127.450(a)(4), a change in ownership of the source shall be treated as an administrative amendment if the Department determines that no other change in the permit is required and a written agreement has been submitted to the Department identifying the specific date of the transfer of permit responsibility, coverage and liability between the current and the new permittee and a compliance review form has been submitted to, and the permit transfer has been approved by, the Department.

(c) This operating permit is valid only for those specific sources and the specific source locations described in this permit.

**#006 [25 Pa. Code § 127.441 and 35 P.S. § 4008]****Inspection and Entry.**

(a) Upon presentation of credentials and other documents as may be required by law, the permittee shall allow the Department or authorized representatives of the Department to perform the following:

(1) Enter at reasonable times upon the permittee's premises where a source is located or emissions related activity is conducted, or where records are kept under the conditions of this permit;

(2) Have access to and copy, at reasonable times, any records that are kept under the conditions of this permit;

(3) Inspect at reasonable times, any facilities, equipment including monitoring and air pollution control equipment, practices, or operations regulated or required under this permit;

(4) Sample or monitor, at reasonable times, any substances or parameters, for the purpose of assuring compliance with the permit or applicable requirements as authorized by the Clean Air Act, the Air Pollution Control Act, or the regulations promulgated under the Acts.

(b) Pursuant to 35 P.S. § 4008, no person shall hinder, obstruct, prevent or interfere with the Department or its personnel in the performance of any duty authorized under the Air Pollution Control Act or regulations adopted thereunder including denying the Department access to a source at this facility. Refusal of entry or access may constitute grounds for permit revocation and assessment of criminal and/or civil penalties.

(c) Nothing in this permit condition shall limit the ability of the EPA to inspect or enter the premises of the permittee in accordance with Section 114 or other applicable provisions of the Clean Air Act.

**#007 [25 Pa. Code §§ 127.441 & 127.444]****Compliance Requirements.**

(a) The permittee shall comply with the conditions of this operating permit. Noncompliance with this permit constitutes a violation of the Clean Air Act and the Air Pollution Control Act and is grounds for one or more of the following:

**SECTION B. General State Only Requirements**

- (1) Enforcement action
- (2) Permit termination, revocation and reissuance or modification
- (3) Denial of a permit renewal application

(b) A person may not cause or permit the operation of a source which is subject to 25 Pa. Code Article III unless the source(s) and air cleaning devices identified in the application for the plan approval and operating permit and the plan approval issued for the source is operated and maintained in accordance with specifications in the applications and the conditions in the plan approval and operating permit issued by the Department. A person may not cause or permit the operation of an air contamination source subject to 25 Pa. Code Chapter 127 in a manner inconsistent with good operating practices.

(c) For purposes of Sub-condition (b) of this permit condition, the specifications in applications for plan approvals and operating permits are the physical configurations and engineering design details which the Department determines are essential for the permittee's compliance with the applicable requirements in this State-Only permit. Nothing in this sub-condition shall be construed to create an independent affirmative duty upon the permittee to obtain a predetermination from the Department for physical configuration or engineering design detail changes made by the permittee.

**#008 [25 Pa. Code § 127.441]****Need to Halt or Reduce Activity Not a Defense.**

It shall not be a defense for the permittee in an enforcement action that it was necessary to halt or reduce the permitted activity in order to maintain compliance with the conditions of this permit.

**#009 [25 Pa. Code §§ 127.442(a) & 127.461]****Duty to Provide Information.**

(a) The permittee shall submit reports to the Department containing information the Department may prescribe relative to the operation and maintenance of each source at the facility.

(b) The permittee shall furnish to the Department, in writing, information that the Department may request to determine whether cause exists for modifying, revoking and reissuing, or terminating this permit, or to determine compliance with the permit. Upon request, the permittee shall also furnish to the Department copies of records that the permittee is required to maintain in accordance with this permit.

**#010 [25 Pa. Code § 127.461]****Revising an Operating Permit for Cause.**

This operating permit may be terminated, modified, suspended or revoked and reissued if one or more of the following applies:

- (1) The permittee constructs or operates the source subject to the operating permit so that it is in violation of the Air Pollution Control Act, the Clean Air Act, the regulations thereunder, a plan approval, a permit or in a manner that causes air pollution.
- (2) The permittee fails to properly or adequately maintain or repair an air pollution control device or equipment attached to or otherwise made a part of the source.
- (3) The permittee has failed to submit a report required by the operating permit or an applicable regulation.
- (4) The EPA determines that the permit is not in compliance with the Clean Air Act or the regulations thereunder.

**#011 [25 Pa. Code §§ 127.450, 127.462, 127.465 & 127.703]****Operating Permit Modifications**

(a) The permittee is authorized to make administrative amendments, minor operating permit modifications and significant operating permit modifications, under this permit, as outlined below:

**SECTION B. General State Only Requirements**

(b) Administrative Amendments. The permittee shall submit the application for administrative operating permit amendments (as defined in 25 Pa. Code § 127.450(a)), according to procedures specified in § 127.450 unless precluded by the Clean Air Act or its regulations.

(c) Minor Operating Permit Modifications. The permittee shall submit the application for minor operating permit modifications (as defined 25 Pa. Code § 121.1) in accordance with 25 Pa. Code § 127.462.

(d) Significant Operating Permit Modifications. The permittee shall submit the application for significant operating permit modifications in accordance with 25 Pa. Code § 127.465.

(e) The applicable fees shall be made payable to "The Commonwealth of Pennsylvania Clean Air Fund" with the permit number clearly indicated and submitted to the respective regional office.

**#012 [25 Pa. Code § 127.441]****Severability Clause.**

The provisions of this permit are severable, and if any provision of this permit is determined by a court of competent jurisdiction to be invalid or unenforceable, such a determination will not affect the remaining provisions of this permit.

**#013 [25 Pa. Code § 127.449]****De Minimis Emission Increases.**

(a) This permit authorizes de minimis emission increases in accordance with 25 Pa. Code § 127.449 so long as the permittee provides the Department with seven (7) days prior written notice before commencing any de minimis emissions increase. The written notice shall:

(1) Identify and describe the pollutants that will be emitted as a result of the de minimis emissions increase.

(2) Provide emission rates expressed in tons per year and in terms necessary to establish compliance consistent with any applicable requirement.

(b) The Department may disapprove or condition de minimis emission increases at any time.

(c) Except as provided below in (d), the permittee is authorized to make de minimis emission increases (expressed in tons per year) up to the following amounts without the need for a plan approval or prior issuance of a permit modification:

(1) Four tons of carbon monoxide from a single source during the term of the permit and 20 tons of carbon monoxide at the facility during the term of the permit.

(2) One ton of NO<sub>x</sub> from a single source during the term of the permit and 5 tons of NO<sub>x</sub> at the facility during the term of the permit.

(3) One and six-tenths tons of the oxides of sulfur from a single source during the term of the permit and 8.0 tons of oxides of sulfur at the facility during the term of the permit.

(4) Six-tenths of a ton of PM<sub>10</sub> from a single source during the term of the permit and 3.0 tons of PM<sub>10</sub> at the facility during the term of the permit. This shall include emissions of a pollutant regulated under Section 112 of the Clean Air Act unless precluded by the Clean Air Act, the regulations thereunder or 25 Pa. Code Article III.

(5) One ton of VOCs from a single source during the term of the permit and 5.0 tons of VOCs at the facility during the term of the permit. This shall include emissions of a pollutant regulated under Section 112 of the Clean Air Act unless precluded by the Clean Air Act, the regulations thereunder or 25 Pa. Code Article III.

(6) Other sources and classes of sources determined to be of minor significance by the Department.

(d) In accordance with § 127.14, the permittee is authorized to install the following minor sources without the need for a plan approval or permit modification:



**SECTION B. General State Only Requirements**

- (1) Air conditioning or ventilation systems not designed to remove pollutants generated or released from other sources.
- (2) Combustion units rated at 2,500,000 or less Btu per hour of heat input.
- (3) Combustion units with a rated capacity of less than 10,000,000 Btu per hour heat input fueled by natural gas supplied by a public utility or by commercial fuel oils which are No. 2 or lighter, viscosity less than or equal to 5.82 c St, and which meet the sulfur content requirements of 25 Pa. Code §123.22 (relating to combustion units). For purposes of this permit, commercial fuel oil shall be virgin oil which has no reprocessed, recycled or waste material added.
- (4) Space heaters which heat by direct heat transfer.
- (5) Laboratory equipment used exclusively for chemical or physical analysis.
- (6) Other sources and classes of sources determined to be of minor significance by the Department.
- (e) This permit does not authorize de minimis emission increases if the emissions increase would cause one or more of the following:
- (1) Increase the emissions of a pollutant regulated under Section 112 of the Clean Air Act except as authorized in Subparagraphs (c)(4) and (5) of this permit condition.
- (2) Subject the facility to the prevention of significant deterioration requirements in 25 Pa. Code Chapter 127, Subchapter D and/or the new source review requirements in Subchapter E.
- (3) Violate any applicable requirement of this permit, the Air Pollution Control Act, the Clean Air Act, or the regulations promulgated under either of the acts.
- (f) Emissions authorized under this permit condition shall be included in the monitoring, recordkeeping and reporting requirements of this permit.
- (g) Except for de minimis emission increases, installation of minor sources made pursuant to this permit condition and Plan Approval Exemptions under 25 Pa. Code § 127.14 (relating to exemptions), the permittee is prohibited from making changes or engaging in activities that are not specifically authorized under this permit without first applying for a plan approval. In accordance with § 127.14(b), a plan approval is not required for the construction, modification, reactivation, or installation of the sources creating the de minimis emissions increase.
- (h) The permittee may not meet de minimis emission threshold levels by offsetting emission increases or decreases at the same source.

**#014 [25 Pa. Code § 127.3]****Operational Flexibility.**

The permittee is authorized to make changes within the facility in accordance with the regulatory provisions outlined in 25 Pa. Code § 127.3 (relating to operational flexibility) to implement the operational flexibility requirements provisions authorized under Section 6.1(i) of the Air Pollution Control Act and the operational flexibility terms and conditions of this permit. The provisions in 25 Pa. Code Chapter 127 which implement the operational flexibility requirements include the following:

- (1) Section 127.14 (relating to exemptions)
- (2) Section 127.447 (relating to alternative operating scenarios)
- (3) Section 127.448 (relating to emissions trading at facilities with Federally enforceable emissions caps)
- (4) Section 127.449 (relating to de minimis emission increases)
- (5) Section 127.450 (relating to administrative operating permit amendments)

**SECTION B. General State Only Requirements**

(6) Section 127.462 (relating to minor operating permit modifications)

(7) Subchapter H (relating to general plan approvals and general operating permits)

**#015 [25 Pa. Code § 127.11]****Reactivation**

(a) The permittee may not reactivate a source that has been out of operation or production for at least one year unless the reactivation is conducted in accordance with a plan approval granted by the Department or in accordance with reactivation and maintenance plans developed and approved by the Department in accordance with 25 Pa. Code § 127.11a(a).

(b) A source which has been out of operation or production for more than five (5) years but less than 10 years may be reactivated and will not be considered a new source if the permittee satisfies the conditions specified in 25 Pa. Code § 127.11a(b).

**#016 [25 Pa. Code § 127.36]****Health Risk-based Emission Standards and Operating Practice Requirements.**

(a) When needed to protect public health, welfare and the environment from emissions of hazardous air pollutants from new and existing sources, the permittee shall comply with the health risk-based emission standards or operating practice requirements imposed by the Department, except as precluded by §§ 6.6(d)(2) and (3) of the Air Pollution Control Act [35 P.S. § 4006.6(d)(2) and (3)].

(b) A person challenging a performance or emission standard established by the Department has the burden to demonstrate that performance or emission standard does not meet the requirements of Section 112 of the Clean Air Act.

**#017 [25 Pa. Code § 121.9]****Circumvention.**

No person may permit the use of a device, stack height which exceeds good engineering practice stack height, dispersion technique or other technique which, without resulting in reduction of the total amount of air contaminants emitted, conceals or dilutes an emission of air contaminants which would otherwise be in violation of 25 Pa. Code Article III, except that with prior approval of the Department, the device or technique may be used for control of malodors.

**#018 [25 Pa. Code §§ 127.402(d) & 127.442]****Reporting Requirements.**

(a) The permittee shall comply with the applicable reporting requirements of the Clean Air Act, the regulations thereunder, the Air Pollution Control Act and 25 Pa. Code Article III including Chapters 127, 135 and 139.

(b) The permittee shall submit reports to the Department containing information the Department may prescribe relative to the operation and maintenance of any air contamination source.

(c) Reports, test data, monitoring data, notifications and requests for renewal of the permit shall be submitted to the:

Regional Air Program Manager  
PA Department of Environmental Protection  
(At the address given in the permit transmittal letter, or otherwise notified)

(d) Any records or information including applications, forms, or reports submitted pursuant to this permit condition shall contain a certification by a responsible official as to truth, accuracy and completeness. The certifications submitted under this permit shall require a responsible official of the facility to certify that based on information and belief formed after reasonable inquiry, the statements and information in the documents are true, accurate and complete.

(e) Any records, reports or information submitted to the Department shall be available to the public except for such

**SECTION B. General State Only Requirements**

records, reports or information which meet the confidentiality requirements of § 4013.2 of the Air Pollution Control Act and §§ 112(d) and 114(c) of the Clean Air Act. The permittee may not request a claim of confidentiality for any emissions data generated for the facility.

**#019 [25 Pa. Code §§ 127.441(c) & 135.5]****Sampling, Testing and Monitoring Procedures.**

(a) The permittee shall comply with the monitoring, recordkeeping or reporting requirements of 25 Pa. Code Chapter 139 and the other applicable requirements of 25 Pa. Code Article III and additional requirements related to monitoring, reporting and recordkeeping required by the Clean Air Act and the regulations thereunder including the Compliance Assurance Monitoring requirements of 40 CFR Part 64, where applicable.

(b) Unless alternative methodology is required by the Clean Air Act and regulations adopted thereunder, sampling, testing and monitoring required by or used by the permittee to demonstrate compliance with any applicable regulation or permit condition shall be conducted in accordance with the requirements of 25 Pa. Code Chapter 139.

**#020 [25 Pa. Code §§ 127.441(c) and 135.5]****Recordkeeping.**

(a) The permittee shall maintain and make available, upon request by the Department, the following records of monitored information:

- (1) The date, place (as defined in the permit) and time of sampling or measurements.
- (2) The dates the analyses were performed.
- (3) The company or entity that performed the analyses.
- (4) The analytical techniques or methods used.
- (5) The results of the analyses.
- (6) The operating conditions as existing at the time of sampling or measurement.

(b) The permittee shall retain records of any required monitoring data and supporting information for at least five (5) years from the date of the monitoring, sample, measurement, report or application. Supporting information includes the calibration data and maintenance records and original strip-chart recordings for continuous monitoring instrumentation, and copies of reports required by the permit.

(c) The permittee shall maintain and make available to the Department upon request, records including computerized records that may be necessary to comply with the reporting, recordkeeping and emission statement requirements in 25 Pa. Code Chapter 135 (relating to reporting of sources). In accordance with 25 Pa. Code Chapter 135, § 135.5, such records may include records of production, fuel usage, maintenance of production or pollution control equipment or other information determined by the Department to be necessary for identification and quantification of potential and actual air contaminant emissions.

**#021 [25 Pa. Code § 127.441(a)]****Property Rights.**

This permit does not convey any property rights of any sort, or any exclusive privileges.

**#022 [25 Pa. Code § 127.447]****Alternative Operating Scenarios.**

The permittee is authorized to make changes at the facility to implement alternative operating scenarios identified in this permit in accordance with 25 Pa. Code § 127.447.

**SECTION B. General State Only Requirements****#023 [25 Pa. Code §135.3]****Reporting**

(a) If the facility is a Synthetic Minor Facility, the permittee shall submit by March 1 of each year an annual emissions report for the preceding calendar year. The report shall include information for all active previously reported sources, new sources which were first operated during the preceding calendar year, and sources modified during the same period which were not previously reported. All air emissions from the facility should be estimated and reported.

(b) A source owner or operator of a Synthetic Minor Facility may request an extension of time from the Department for the filing of an annual emissions report, and the Department may grant the extension for reasonable cause.

**#024 [25 Pa. Code §135.4]****Report Format**

If applicable, the emissions reports shall contain sufficient information to enable the Department to complete its emission inventory. Emissions reports shall be made by the source owner or operator in a format specified by the Department.

**SECTION C. Site Level Requirements****I. RESTRICTIONS.****Emission Restriction(s).****# 001 [25 Pa. Code §121.7]****Prohibition of air pollution.**

No person may permit air pollution as that term is defined in the act.

**# 002 [25 Pa. Code §123.1]****Prohibition of certain fugitive emissions**

(a) No person may permit the emission into the outdoor atmosphere of fugitive air contaminant from a source other than the following:

- (1) Construction or demolition of buildings or structures.
- (2) Grading, paving and maintenance of roads and streets.
- (3) Use of roads and streets. Emissions from material in or on trucks, railroad cars and other vehicular equipment are not considered as emissions from use of roads and streets.
- (4) Clearing of land.
- (5) Stockpiling of materials.
- (6) Open burning operations.
- (7) Blasting in open pit mines. Emissions from drilling are not considered as emissions from blasting.
- (8) Not applicable.

(9) Sources and classes of sources other than those identified in paragraphs (1)-(8), for which the operator has obtained a determination from the Department that fugitive emissions from the source, after appropriate control, meet the following requirements:

- (i) the emissions are of minor significance with respect to causing air pollution; and
- (ii) the emissions are not preventing or interfering with the attainment or maintenance of any ambient air quality standard.

(b) Not applicable.

(c) See Work Practice Standards.

(d) Not applicable.

**# 003 [25 Pa. Code §123.13]****Processes**

(c) For processes not listed in subsection (b)(1), including, but not limited to, coke oven battery waste heat stacks and autogeneous zinc coker waste heat stacks, the following apply:

(1) Prohibited emissions. No person may permit the emission into the outdoor atmosphere of particulate matter from a process not listed in subsection (b)(1) in a manner that the concentration of particulate matter in the effluent gas exceeds any of the following:

- (i) .04 grain per dry standard cubic foot, when the effluent gas volume is less than 150,000 dry standard cubic feet per minute.
- (ii) The rate determined by the following formula:  $A = 6000 E^{-1}$   
where: A = Allowable emissions in grains per dry standard cubic foot, and  
E = Effluent gas volume in dry standard cubic feet per minute, when  
E is equal to or greater than 150,000 but less than 300,000.

(iii) .02 grain per dry standard cubic foot, when the effluent gas volume is greater than 300,000 dry standard cubic feet per minute.

(2) Allowable emissions. Allowable emissions under this subsection are graphically indicated in Appendix C.

**# 004 [25 Pa. Code §123.2]****Fugitive particulate matter**

A person may not permit fugitive particulate matter to be emitted into the outdoor atmosphere from a source specified in 123.1(a)(1) -- (9) (relating to prohibition of certain fugitive emissions) if such emissions are visible at the point the emissions pass outside the person's property.

**SECTION C. Site Level Requirements****# 005 [25 Pa. Code §123.31]****Limitations**

- (a) Not applicable.
- (b) A person may not permit the emission into the outdoor atmosphere of any malodorous air contaminants from any source in such a manner that the malodors are detectable outside the property of the person on whose land the source is being operated.
- (c) Not applicable.

**# 006 [25 Pa. Code §123.41]****Limitations**

A person may not permit the emission into the outdoor atmosphere of visible air contaminants in such a manner that the opacity of the emission is either of the following:

- (1) Equal to or greater than 20% for a period or periods aggregating more than three minutes in any 1 hour.
- (2) Equal to or greater than 60% at any time.

**# 007 [25 Pa. Code §123.42]****Exceptions**

The limitations of 123.41 (relating to limitations) shall not apply to a visible emission in any of the following instances:

- (1) When the presence of uncombined water is the only reason for failure of the emission to meet the limitations.
- (2) When the emission results from the operation of equipment used solely to train and test persons in observing the opacity of visible emissions.
- (3) When the emission results from sources specified in 123.1(a)(1) -- (9) (relating to prohibition of certain fugitive emissions).
- (4) Not applicable.

**# 008 [25 Pa. Code §129.14]****Open burning operations**

- (a) Air basins. Not applicable.
- (b) Outside of air basins. No person may permit the open burning of material in an area outside of air basins in a manner that:
  - (1) The emissions are visible, at any time, at the point such emissions pass outside the property of the person on whose land the open burning is being conducted.
  - (2) Malodorous air contaminants from the open burning are detectable outside the property of the person on whose land the open burning is being conducted.
  - (3) The emissions interfere with the reasonable enjoyment of life or property.
  - (4) The emissions cause damage to vegetation or property.
  - (5) The emissions are or may be deleterious to human or animal health.
- (c) Exceptions: The requirements of subsections (a) and (b) do not apply where the open burning operations result from:
  - (1) A fire set to prevent or abate a fire hazard, when approved by the Department and set by or under the supervision of a public officer.
  - (2) A fire set for the purpose of instructing personnel in fire fighting, when approved by the Department.
  - (3) A fire set for the prevention and control of disease or pests, when approved by the Department.
  - (4) Not applicable.
  - (5) Not applicable.
  - (6) A fire set solely for recreational or ceremonial purposes.
  - (7) A fire set solely for cooking food.

- (d) Clearing and grubbing wastes. The following is applicable to clearing and grubbing wastes:

- (1) As used in this subsection the following terms shall have the following meanings:

Air curtain destructor -- A mechanical device which forcefully projects a curtain of air across a pit in which open burning is being conducted so that combustion efficiency is increased and smoke and other particulate matter are contained.

Clearing and grubbing wastes -- Trees, shrubs, and other native vegetation which are cleared from land during or prior to

**SECTION C. Site Level Requirements**

the process of construction. The term does not include demolition wastes and dirt laden roots.

(2) Subsection (a) notwithstanding, clearing and grubbing wastes may be burned in a basin subject to the following requirements:

(i) Air curtain destructors shall be used when burning clearing and grubbing wastes.

(ii) Each proposed use of air curtain destructors shall be reviewed and approved by the Department in writing with respect to equipment arrangement, design and existing environmental conditions prior to commencement of burning. Proposals approved under this subparagraph need not obtain plan approval or operating permits under Chapter 127 (relating to construction modification, reactivation and operation of sources).

(iii) Approval for use of an air curtain destructor at one site may be granted for a specified period not to exceed 3 months, but may be extended for additional limited periods upon further approval by the Department.

(iv) The Department reserves the right to rescind approval granted if a determination by the Department indicates that an air pollution problem exists.

(3) Subsection (b) notwithstanding clearing and grubbing wastes may be burned outside of an air basin, subject to the following limitations:

(i) Upon receipt of a complaint or determination by the Department that an air pollution problem exists, the Department may order that the open burning cease or comply with subsection (b) of this section.

(ii) Authorization for open burning under this paragraph does not apply to clearing and grubbing wastes transported from an air basin for disposal outside of an air basin.

(4) During an air pollution episode, open burning is limited by Chapter 137 (relating to air pollution episodes) and shall cease as specified in such chapter.

**II. TESTING REQUIREMENTS.**

**# 009 [25 Pa. Code §127.441]**

**Operating permit terms and conditions.**

The Department reserves the right to require exhaust stack testing of any source as necessary to verify emissions for purposes including determining the correct emission fee, malfunctions, and determining compliance with any applicable requirement.

**III. MONITORING REQUIREMENTS.**

**# 010 [25 Pa. Code §123.43]**

**Measuring techniques**

Visible emissions may be measured using either of the following:

(1) A device approved by the Department and maintained to provide accurate opacity measurements.

(2) Observers, trained and qualified to measure plume opacity with the naked eye or with the aid of any devices approved by the Department.

**# 011 [25 Pa. Code §127.441]**

**Operating permit terms and conditions.**

A facility-wide inspection shall be conducted at a minimum of once each day that sources at the facility are operating. The facility-wide inspection shall be conducted for the presence of the following:

1. Visible stack emissions;
2. Fugitive emissions; and
3. Potentially objectionable odors at the property line.

These observations are to ensure continued compliance with source-specific visible emission limitations, fugitive emissions prohibited under 25 Pa. Code § 123.1 or 25 Pa. Code § 123.2, and malodors prohibited under 25 Pa. Code §123.31. Observations for visible stack emissions shall be conducted during daylight hours and all observations shall be conducted while sources are in operation. If any visible stack emissions, fugitive emissions, or potentially objectionable odors are apparent, the Owner/Operator shall take corrective action. These observations determine whether, or not, these conditions exist. They do not quantify the level of existing conditions. Therefore, the observations for presence, or lack of, visible emissions do not require that they be performed by a person certified as a qualified observer for EPA Method 9 for Visual Determination of the Opacity of Emissions from Stationary Sources.

**SECTION C. Site Level Requirements**

Equipment at the plant shall not operate in violation of 25 Pa. Code § 123.1 and 25 Pa. Code § 123.2.

**IV. RECORDKEEPING REQUIREMENTS.****# 012 [25 Pa. Code §127.441]****Operating permit terms and conditions.**

The permittee shall maintain a daily record of all inspections conducted for visible stack emissions, fugitive emissions, or potentially objectionable odors. The records shall include the date, time, name and title of the observer, whether visible stack emissions, fugitive emissions, or potentially objectionable odors were observed, and any corrective action. Records shall be kept on-site for a minimum of five years and made available to the Department upon request.

**# 013 [25 Pa. Code §127.441]****Operating permit terms and conditions.**

The owner/operator shall maintain a monthly log of the hours of operation, tons of stone delivered to the plant, inventory on hand, and tons of stone shipped from the facility. The log shall be maintained on site for a minimum of five years and shall be made available to the Department upon request.

**V. REPORTING REQUIREMENTS.****# 014 [25 Pa. Code §127.442]****Reporting requirements.**

- (a) The permittee shall report malfunctions, emergencies or incidents of excess emissions to the Department. A malfunction is any sudden, infrequent, and not reasonably preventable failure of air pollution control equipment, process equipment, or a process to operate in a normal or usual manner. An emergency is any situation arising from sudden and reasonably unforeseeable events beyond the control of the owner or operator of a facility which requires immediate corrective action to restore normal operation and which causes the emission source to exceed emissions, due to unavoidable increases in emissions attributable to the situation. An emergency shall not include situations caused by improperly designed equipment, lack of preventive maintenance, careless or improper operation, or operator error.
- (b) When the malfunction, emergency or incident of excess emissions poses an imminent danger to the public health, safety, welfare, or environment, it shall be reported to the Department and the County Emergency Management Agency by telephone within one (1) hour after the discovery of the malfunction, emergency or incident of excess emissions. The owner or operator shall submit a written or emailed report of instances of such malfunctions, emergencies or incidents of excess emissions to the Department within three (3) business days of the telephone report.
- (c) The report shall describe the following:
1. name, permit or authorization number, and location of the facility,
  2. nature and cause of the malfunction, emergency or incident,
  3. date and time when the malfunction, emergency or incident was first observed,
  4. expected duration of excess emissions,
  5. estimated rate of emissions,
  6. corrective actions or preventative measures taken.
- (d) Any malfunction, emergency or incident of excess emissions that is not subject to the notice requirements of paragraph (b) of this condition shall be reported to the Department by telephone within 24 hours (or by 4:00 PM of the next business day, whichever is later) of discovery and in writing or by e-mail within five (5) business days of discovery. The report shall contain the same information required by paragraph (c), and any permit specific malfunction reporting requirements.
- (e) During an emergency an owner or operator may continue to operate the source at their discretion provided they submit justification for continued operation of a source during the emergency and follow all the notification and reporting requirements in accordance with paragraphs (b)-(d), as applicable, including any permit specific malfunction reporting requirements.
- (f) Reports regarding malfunctions, emergencies or incidents of excess emissions shall be submitted to the appropriate



**SECTION C. Site Level Requirements**

DEP Regional Office Air Program Manager.

(g) Any emissions resulted from malfunction or emergency are to be reported in the annual emissions inventory report, if the annual emissions inventory report is required by permit or authorization.

**# 015 [25 Pa. Code §135.3]****Reporting**

(a) A person who owns or operates a source to which this chapter applies, and who has previously been advised by the Department to submit a source report, shall submit by March 1 of each year a source report for the preceding calendar year. The report shall include information for all previously reported sources, new sources which were first operated during the preceding calendar year and sources modified during the same period which were not previously reported.

(b) A person who receives initial notification by the Department that a source report is necessary shall submit an initial source report with 60 days after receiving the notification or by March 1 of the year following the year for which the report is required, whichever is later.

(c) A source owner or operator may request an extension of time from the Department for the filing of a source report, and the Department may grant the extension for reasonable cause.

**VI. WORK PRACTICE REQUIREMENTS.****# 016 [25 Pa. Code §123.1]****Prohibition of certain fugitive emissions**

(c) A person responsible for any source specified in subsections (a)(1) -- (7) or (9) shall take all reasonable actions to prevent particulate matter from becoming airborne. These actions shall include, but not be limited to, the following:

- (1) Use, where possible, of water or chemicals for control of dust in the demolition of buildings or structures, construction operations, the grading of roads, or the clearing of land.
- (2) Application of asphalt, oil, water or suitable chemicals on dirt roads, material stockpiles and other surfaces which may give rise to airborne dusts.
- (3) Paving and maintenance of roadways.
- (4) Prompt removal of earth or other material from paved streets onto which earth or other material has been transported by trucking or earth moving equipment, erosion by water, or other means.

**# 017 [25 Pa. Code §127.441]****Operating permit terms and conditions.**

a) Conveying equipment, stackers (except fixed height conveyors) and front-end loaders used to transfer, stockpile, and load aggregate shall maintain a minimal amount of drop height, as practicable, to prevent fugitive emissions.

b) Stockpiles shall be kept as compact as possible to limit exposure to the wind. Material shall be stockpiled in such a manner that it may be adequately wetted as necessary to control fugitive emissions.

c) Water sprays must be operating at all times the processing plant is in operation.

**# 018 [25 Pa. Code §127.441]****Operating permit terms and conditions.**

The owner or operator shall keep on hand the manufacturer's recommended number of spare bags for baghouse repair.

**# 019 [25 Pa. Code §127.441]****Operating permit terms and conditions.**

The permittee shall operate all air contamination sources and air cleaning devices at this facility in accordance with available manufacturer's specifications.

**VII. ADDITIONAL REQUIREMENTS.****# 020 [40 CFR Part 60 Standards of Performance for New Stationary Sources §40 CFR 60.670]****Subpart OOO - Standards of Performance for Nonmetallic Mineral Processing Plants****Applicability and designation of affected facility.**

This facility is subject to New Source Performance Standards for Nonmetallic Mineral Processing Plants, Subpart OOO. In accordance with 40 CFR 60.4, copies of all requests, reports, applications, submittals and other communications shall be

**SECTION C. Site Level Requirements**

forwarded to both the US EPA and the Department at the address below unless otherwise noted.

PA DEP  
Office of Air Quality Control  
400 Waterfront Drive  
Pittsburgh, PA 15222

US EPA, Region III  
Air Toxics and Radiation  
1650 Arch Street  
Philadelphia, PA 19103-2029

**VIII. COMPLIANCE CERTIFICATION.**

No additional compliance certifications exist except as provided in other sections of this permit including Section B (relating to State Only General Requirements).

**IX. COMPLIANCE SCHEDULE.**

No compliance milestones exist.

**SECTION D. Source Level Requirements**

Source ID: 108

Source Name: CRUSHING/SCREENING PLANT

Source Capacity/Throughput: 1,500.000 Tons/HR LIMESTONE

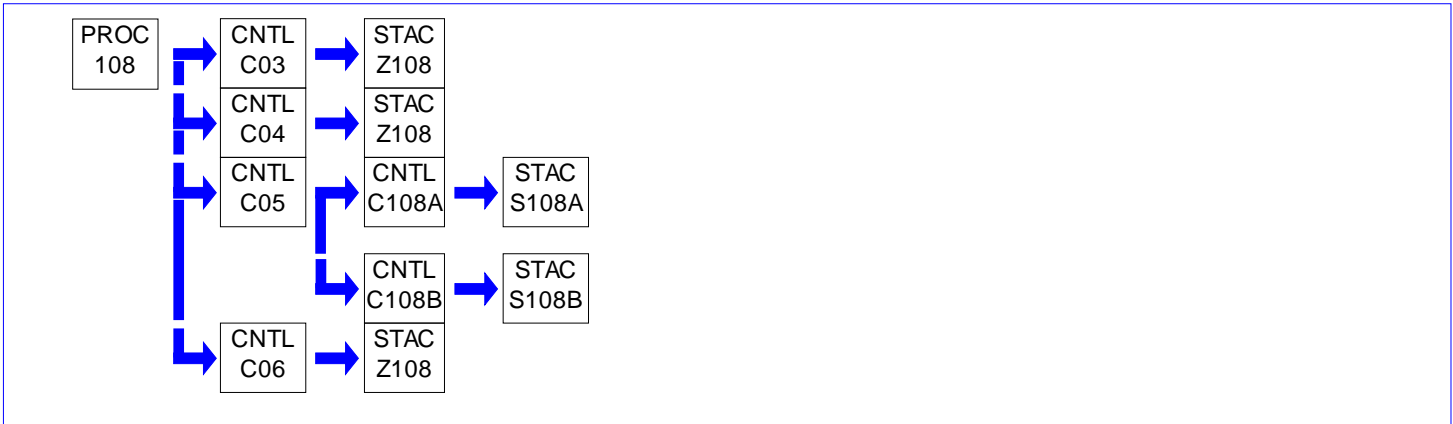

**I. RESTRICTIONS.**

**Emission Restriction(s).**

**# 001 [25 Pa. Code §123.13]**

**Processes**

(a)-(b) Not applicable.

(c) For processes not listed in subsection (b)(1), including but not limited to, coke oven battery waste heat stacks and autogeneous zinc coker waste heat stacks, the following shall apply:

(1) Prohibited emissions. No person may permit the emission into the outdoor atmosphere of particulate matter from any process not listed in subsection (b)(1) in a manner that the concentration of particulate matter in the effluent gas exceeds any of the following:

(i) .04 grain per dry standard cubic foot, when the effluent gas volume is less than 150,000 dry standard cubic feet per minute.

(ii) The rate determined by the formula:

$$A = 6000/E$$

where:

A = Allowable emissions in grains per dry standard cubic foot, and

E = Effluent gas volume in dry standard cubic feet per minute,

when E is equal to or greater than 150,000 but less than 300,000.

(iii) Not applicable.

(d) Not applicable.

**# 002 [25 Pa. Code §127.441]**

**Operating permit terms and conditions.**

The Deister 7x16 screen rated at 890 tph is limited to 1,800 hours of operation over a 12-month rolling period.

**# 003 [25 Pa. Code §127.441]**

**Operating permit terms and conditions.**

Table 2 to Subpart 000 - Stack Emission Limits for Affected Facilities With Capture Systems

[Facility IDs: #007, #008, #020]

a) For affected facilities (as defined in §§60.670 and 60.671) that commenced construction, modification, or reconstruction after August 31, 1983 but before April 22, 2008, the owner or operator must meet a PM limit of 0.05 g/dscm (0.022 gr/dscf)\* and an opacity limit of 7 percent for dry control devices\*\*. The owner or operator must demonstrate compliance with these limits by conducting an initial performance test according to §60.8 of this part and §60.675 of this subpart; and monitoring of

**SECTION D. Source Level Requirements**

wet scrubber parameters according to §60.674(a) and §60.676(c), (d), and (e).

b) For affected facilities (as defined in §§60.670 and 60.671) that commence construction, modification, or reconstruction on or after April 22, 2008, the owner or operator must meet a PM limit of 0.032 g/dscm (0.014 gr/dscf)\* and 7 percent for dry control devices on individual enclosed storage bins. The owner or operator must demonstrate compliance with these limits by conducting an initial performance test according to §60.8 of this part and §60.675 of this subpart; monitoring of wet scrubber parameters according to §60.674(a) and §60.676(c), (d), and (e); and monitoring of baghouses according to §60.674(c), (d), or (e) and §60.676(b).

\*\*The stack opacity limit and associated opacity testing requirements do not apply for affected facilities using wet scrubbers.

**# 004 [25 Pa. Code §127.441]****Operating permit terms and conditions.**

Table 3 to Subpart 000 - Fugitive Emission Limits  
[Facility IDs: #003, #011, #015, #016, #017]

a) For affected facilities (as defined in §§60.670 and 60.671) that commenced construction, modification, or reconstruction after August 31, 1983 but before April 22, 2008, the owner or operator must meet 10 percent opacity fugitive emissions limit for grinding mills, screening operations, bucket elevators, transfer points on belt conveyors, bagging operations, storage bins, enclosed truck or railcar loading stations or from any other affected facility (as defined in §§60.670 and 60.671) and 15 percent opacity fugitive emissions limit for crushers at which a capture system is not used. The owner or operator must demonstrate compliance with these limits by conducting an initial performance test according to §60.11 of this part and §60.675 of this subpart.

b) For affected facilities (as defined in §§60.670 and 60.671) that commence construction, modification, or reconstruction on or after April 22, 2008, the owner or operator must meet 7 percent opacity fugitive emissions limit for grinding mills, screening operations, bucket elevators, transfer points on belt conveyors, bagging operations, storage bins, enclosed truck or railcar loading stations or from any other affected facility (as defined in §§60.670 and 60.671) and 12 percent opacity fugitive emissions limit for crushers at which a capture system is not used. The owner or operator must demonstrate compliance with these limits by conducting an initial performance test according to §60.11 of this part and §60.675 of this subpart; periodic inspections of water sprays according to §60.674(b) and §60.676(b); and a repeat performance test according to §60.11 of this part and §60.675 of this subpart within 5 years from the previous performance test for fugitive emissions from affected facilities without water sprays. Affected facilities controlled by water carryover from upstream water sprays that are inspected according to the requirements in §60.674(b) and §60.676(b) are exempt from this 5-year repeat testing requirement.

**# 005 [40 CFR Part 60 Standards of Performance for New Stationary Sources §40 CFR 60.672]****Subpart 000 - Standards of Performance for Nonmetallic Mineral Processing Plants  
Standard for particulate matter.**

(a) Affected facilities must meet the stack emission limits and compliance requirements in Table 2 of this subpart within 60 days after achieving the maximum production rate at which the affected facility will be operated, but not later than 180 days after initial startup as required under §60.8. The requirements in Table 2 of this subpart apply for affected facilities with capture systems used to capture and transport particulate matter to a control device.  
[Facility IDs: #007, #008, #020]

(b) Affected facilities must meet the fugitive emission limits and compliance requirements in Table 3 of this subpart within 60 days after achieving the maximum production rate at which the affected facility will be operated, but not later than 180 days after initial startup as required under §60.11. The requirements in Table 3 of this subpart apply for fugitive emissions from affected facilities without capture systems and for fugitive emissions escaping capture systems.  
[Facility IDs: #003, #011, #015, #016, #017]

(c) [Reserved]

(d) Truck dumping of nonmetallic minerals into any screening operation, feed hopper, or crusher is exempt from the requirements of this section.

**SECTION D. Source Level Requirements**

(e)-(f) Not applicable.

**II. TESTING REQUIREMENTS.****# 006 [40 CFR Part 60 Standards of Performance for New Stationary Sources §40 CFR 60.675]****Subpart 000 - Standards of Performance for Nonmetallic Mineral Processing Plants****Test methods and procedures.**

(a) In conducting the performance tests required in §60.8, the owner or operator shall use as reference methods and procedures the test methods in appendices A-1 through A-7 of this part or other methods and procedures as specified in this section, except as provided in §60.8(b). Acceptable alternative methods and procedures are given in paragraph (e) of this section.

(b) The owner or operator shall determine compliance with the PM standards in §60.672(a) as follows:

(1) Except as specified in paragraphs (e)(3) and (4) of this section, Method 5 of Appendix A-3 of this part or Method 17 of Appendix A-6 of this part shall be used to determine the particulate matter concentration. The sample volume shall be at least 1.70 dscm (60 dscf). For Method 5 (40 CFR part 60, Appendix A-3), if the gas stream being sampled is at ambient temperature, the sampling probe and filter may be operated without heaters. If the gas stream is above ambient temperature, the sampling probe and filter may be operated at a temperature high enough, but no higher than 121 °C (250 °F), to prevent water condensation on the filter.

(2) Method 9 of Appendix A-4 of this part and the procedures in §60.11 shall be used to determine opacity.

(c)

(1) In determining compliance with the particulate matter standards in §60.672(b) or §60.672(e)(1), the owner or operator shall use Method 9 of Appendix A-4 of this part and the procedures in §60.11, with the following additions:

(i) The minimum distance between the observer and the emission source shall be 4.57 meters (15 feet).

(ii) The observer shall, when possible, select a position that minimizes interference from other fugitive emission sources (e.g., road dust). The required observer position relative to the sun (Method 9 of Appendix A-4 of this part, Section 2.1) must be followed.

(iii) For affected facilities using wet dust suppression for particulate matter control, a visible mist is sometimes generated by the spray. The water mist must not be confused with particulate matter emissions and is not to be considered a visible emission. When a water mist of this nature is present, the observation of emissions is to be made at a point in the plume where the mist is no longer visible.

(2)(i) Not applicable.

(3) When determining compliance with the fugitive emissions standard for any affected facility described under §60.672(b) or §60.672(e)(1) of this subpart, the duration of the Method 9 (40 CFR part 60, Appendix A-4) observations must be 30 minutes (five 6-minute averages). Compliance with the applicable fugitive emission limits in Table 3 of this subpart must be based on the average of the five 6-minute averages.

(d) Not applicable.

(e) The owner or operator may use the following as alternatives to the reference methods and procedures specified in this section:

(1) For the method and procedure of paragraph (c) of this section, if emissions from two or more facilities continuously

**SECTION D. Source Level Requirements**

interfere so that the opacity of fugitive emissions from an individual affected facility cannot be read, either of the following procedures may be used:

(i) Use for the combined emission stream the highest fugitive opacity standard applicable to any of the individual affected facilities contributing to the emissions stream.

(ii) Separate the emissions so that the opacity of emissions from each affected facility can be read.

(2) A single visible emission observer may conduct visible emission observations for up to three fugitive, stack, or vent emission points within a 15-second interval if the following conditions are met:

(i) No more than three emission points may be read concurrently.

(ii) All three emission points must be within a 70 degree viewing sector or angle in front of the observer such that the proper sun position can be maintained for all three points.

(iii) If an opacity reading for any one of the three emission points equals or exceeds the applicable standard, then the observer must stop taking readings for the other two points and continue reading just that single point.

(3) Method 5l of Appendix A-3 of this part may be used to determine the PM concentration as an alternative to the methods specified in paragraph (b)(1) of this section. Method 5l (40 CFR part 60, Appendix A-3) may be useful for affected facilities that operate for less than 1 hour at a time such as (but not limited to) storage bins or enclosed truck or railcar loading stations.

(4) Not applicable.

(f) To comply with §60.676(d), the owner or operator shall record the measurements as required in §60.676(c) using the monitoring devices in §60.674 (a)(1) and (2) during each particulate matter run and shall determine the averages.

(g) For performance tests involving only Method 9 (40 CFR part 60 Appendix A-4) testing, the owner or operator may reduce the 30-day advance notification of performance test in §60.7(a)(6) and 60.8(d) to a 7-day advance notification.

(h) [Reserved]

(i) If the initial performance test date for an affected facility falls during a seasonal shut down (as defined in §60.671 of this subpart) of the affected facility, then with approval from the permitting authority, the owner or operator may postpone the initial performance test until no later than 60 calendar days after resuming operation of the affected facility.

**III. MONITORING REQUIREMENTS.**

**# 007 [40 CFR Part 60 Standards of Performance for New Stationary Sources §40 CFR 60.674]**

**Subpart 000 - Standards of Performance for Nonmetallic Mineral Processing Plants**

**Monitoring of operations.**

(a) Not applicable

(b) The owner or operator of any affected facility for which construction, modification, or reconstruction commenced on or after April 22, 2008, that uses wet suppression to control emissions from the affected facility must perform monthly periodic inspections to check that water is flowing to discharge spray nozzles in the wet suppression system. The owner or operator must initiate corrective action within 24 hours and complete corrective action as expeditiously as practical if the owner or operator finds that water is not flowing properly during an inspection of the water spray nozzles. The owner or operator must record each inspection of the water spray nozzles, including the date of each inspection and any corrective actions taken, in the logbook required under §60.676(b).

(1) If an affected facility relies on water carryover from upstream water sprays to control fugitive emissions, then that affected facility is exempt from the 5-year repeat testing requirement specified in Table 3 of this subpart provided that the affected facility meets the criteria in paragraphs (b)(1)(i) and (ii) of this section:

**SECTION D. Source Level Requirements**

- (i) The owner or operator of the affected facility conducts periodic inspections of the upstream water spray(s) that are responsible for controlling fugitive emissions from the affected facility. These inspections are conducted according to paragraph (b) of this section and §60.676(b), and
- (ii) The owner or operator of the affected facility designates which upstream water spray(s) will be periodically inspected at the time of the initial performance test required under §60.11 of this part and §60.675 of this subpart.
- (2) If an affected facility that routinely uses wet suppression water sprays ceases operation of the water sprays or is using a control mechanism to reduce fugitive emissions other than water sprays during the monthly inspection (for example, water from recent rainfall), the logbook entry required under §60.676(b) must specify the control mechanism being used instead of the water sprays.
- (c) Except as specified in paragraph (d) or (e) of this section, the owner or operator of any affected facility for which construction, modification, or reconstruction commenced on or after April 22, 2008, that uses a baghouse to control emissions must conduct quarterly 30-minute visible emissions inspections using EPA Method 22 (40 CFR part 60, appendix A-7). The Method 22 (40 CFR part 60, appendix A-7) test shall be conducted while the baghouse is operating. The test is successful if no visible emissions are observed. If any visible emissions are observed, the owner or operator of the affected facility must initiate corrective action within 24 hours to return the baghouse to normal operation. The owner or operator must record each Method 22 (40 CFR part 60, appendix A-7) test, including the date and any corrective actions taken, in the logbook required under §60.676(b). The owner or operator of the affected facility may establish a different baghouse-specific success level for the visible emissions test (other than no visible emissions) by conducting a PM performance test according to §60.675(b) simultaneously with a Method 22 (40 CFR part 60, appendix A-7) to determine what constitutes normal visible emissions from that affected facility's baghouse when it is in compliance with the applicable PM concentration limit in Table 2 of this subpart. The revised visible emissions success level must be incorporated into the permit for the affected facility.
- (d) As an alternative to the periodic Method 22 (40 CFR part 60, appendix A-7) visible emissions inspections specified in paragraph (c) of this section, the owner or operator of any affected facility for which construction, modification, or reconstruction commenced on or after April 22, 2008, that uses a baghouse to control emissions may use a bag leak detection system. The owner or operator must install, operate, and maintain the bag leak detection system according to paragraphs (d)(1) through (3) of this section.
- (1) Each bag leak detection system must meet the specifications and requirements in paragraphs (d)(1)(i) through (viii) of this section.
- (i) The bag leak detection system must be certified by the manufacturer to be capable of detecting PM emissions at concentrations of 1 milligram per dry standard cubic meter (0.00044 grains per actual cubic foot) or less.
- (ii) The bag leak detection system sensor must provide output of relative PM loadings. The owner or operator shall continuously record the output from the bag leak detection system using electronic or other means (e.g., using a strip chart recorder or a data logger).
- (iii) The bag leak detection system must be equipped with an alarm system that will sound when the system detects an increase in relative particulate loading over the alarm set point established according to paragraph (d)(1)(iv) of this section, and the alarm must be located such that it can be heard by the appropriate plant personnel.
- (iv) In the initial adjustment of the bag leak detection system, the owner or operator must establish, at a minimum, the baseline output by adjusting the sensitivity (range) and the averaging period of the device, the alarm set points, and the alarm delay time.
- (v) Following initial adjustment, the owner or operator shall not adjust the averaging period, alarm set point, or alarm delay time without approval from the Administrator or delegated authority except as provided in paragraph (d)(1)(vi) of this section.
- (vi) Once per quarter, the owner or operator may adjust the sensitivity of the bag leak detection system to account for seasonal effects, including temperature and humidity, according to the procedures identified in the site-specific monitoring plan required by paragraph (d)(2) of this section.
- (vii) The owner or operator must install the bag leak detection sensor downstream of the fabric filter.
- (viii) Where multiple detectors are required, the system's instrumentation and alarm may be shared among detectors.
- (2) The owner or operator of the affected facility must develop and submit to the Administrator or delegated authority for approval of a site-specific monitoring plan for each bag leak detection system. The owner or operator must operate and maintain the bag leak detection system according to the site-specific monitoring plan at all times. Each monitoring plan must describe the items in paragraphs (d)(2)(i) through (vi) of this section.

**SECTION D. Source Level Requirements**

- (i) Installation of the bag leak detection system;
- (ii) Initial and periodic adjustment of the bag leak detection system, including how the alarm set-point will be established;
- (iii) Operation of the bag leak detection system, including quality assurance procedures;
- (iv) How the bag leak detection system will be maintained, including a routine maintenance schedule and spare parts inventory list;
- (v) How the bag leak detection system output will be recorded and stored; and
- (vi) Corrective action procedures as specified in paragraph (d)(3) of this section. In approving the site-specific monitoring plan, the Administrator or delegated authority may allow owners and operators more than 3 hours to alleviate a specific condition that causes an alarm if the owner or operator identifies in the monitoring plan this specific condition as one that could lead to an alarm, adequately explains why it is not feasible to alleviate this condition within 3 hours of the time the alarm occurs, and demonstrates that the requested time will ensure alleviation of this condition as expeditiously as practicable.

(3) For each bag leak detection system, the owner or operator must initiate procedures to determine the cause of every alarm within 1 hour of the alarm. Except as provided in paragraph (d)(2)(vi) of this section, the owner or operator must alleviate the cause of the alarm within 3 hours of the alarm by taking whatever corrective action(s) are necessary. Corrective actions may include, but are not limited to the following:

- (i) Inspecting the fabric filter for air leaks, torn or broken bags or filter media, or any other condition that may cause an increase in PM emissions;
- (ii) Sealing off defective bags or filter media;
- (iii) Replacing defective bags or filter media or otherwise repairing the control device;
- (iv) Sealing off a defective fabric filter compartment;
- (v) Cleaning the bag leak detection system probe or otherwise repairing the bag leak detection system; or
- (vi) Shutting down the process producing the PM emissions.

(e) As an alternative to the periodic Method 22 (40 CFR part 60, appendix A-7) visible emissions inspections specified in paragraph (c) of this section, the owner or operator of any affected facility that is subject to the requirements for processed stone handling operations in the Lime Manufacturing NESHAP (40 CFR part 63, subpart AAAAA) may follow the continuous compliance requirements in row 1 items (i) through (iii) of table 6 to subpart AAAAA of 40 CFR part 63.

**IV. RECORDKEEPING REQUIREMENTS.****# 008 [25 Pa. Code §127.441]****Operating permit terms and conditions.**

The owner/operator shall maintain a monthly log of the hours of operation for the Deister 7x16 screen rated at 890 tph, totalled monthly on a 12-month rolling basis. This record shall be maintained on-site for a minimum of five years and made available to the Department upon request.

**# 009 [40 CFR Part 60 Standards of Performance for New Stationary Sources §40 CFR 60.676]****Subpart 000 - Standards of Performance for Nonmetallic Mineral Processing Plants****Reporting and recordkeeping.**

(a) Each owner or operator seeking to comply with §60.670(d) shall submit to the Administrator the following information about the existing facility being replaced and the replacement piece of equipment.

- (1) For a crusher, grinding mill, bucket elevator, bagging operation, or enclosed truck or railcar loading station:
  - (i) The rated capacity in megagrams or tons per hour of the existing facility being replaced and
  - (ii) The rated capacity in tons per hour of the replacement equipment.
- (2) For a screening operation:
  - (i) The total surface area of the top screen of the existing screening operation being replaced and
  - (ii) The total surface area of the top screen of the replacement screening operation.
- (3) For a conveyor belt:
  - (i) The width of the existing belt being replaced and
  - (ii) The width of the replacement conveyor belt.



**SECTION D. Source Level Requirements**

(4) For a storage bin:

- (i) The rated capacity in megagrams or tons of the existing storage bin being replaced and
- (ii) The rated capacity in megagrams or tons of replacement storage bins.

(b)(1) Owners or operators of affected facilities (as defined in §§60.670 and 60.671) for which construction, modification, or reconstruction commenced on or after April 22, 2008, must record each periodic inspection required under §60.674(b) or (c), including dates and any corrective actions taken, in a logbook (in written or electronic format). The owner or operator must keep the logbook onsite and make hard or electronic copies (whichever is requested) of the logbook available to the Administrator upon request.

(2) For each bag leak detection system installed and operated according to §60.674(d), the owner or operator must keep the records specified in paragraphs (b)(2)(i) through (iii) of this section.

- (i) Records of the bag leak detection system output;
- (ii) Records of bag leak detection system adjustments, including the date and time of the adjustment, the initial bag leak detection system settings, and the final bag leak detection system settings; and
- (iii) The date and time of all bag leak detection system alarms, the time that procedures to determine the cause of the alarm were initiated, the cause of the alarm, an explanation of the actions taken, the date and time the cause of the alarm was alleviated, and whether the cause of the alarm was alleviated within 3 hours of the alarm.

(3) The owner or operator of each affected facility demonstrating compliance according to §60.674(e) by following the requirements for processed stone handling operations in the Lime Manufacturing NESHAP (40 CFR part 63, subpart AAAAA) must maintain records of visible emissions observations required by §63.7132(a)(3) and (b) of 40 CFR part 63, subpart AAAAA.

(c)-(e) Not applicable.

(f) The owner or operator of any affected facility shall submit written reports of the results of all performance tests conducted to demonstrate compliance with the standards set forth in §60.672 of this subpart, including reports of opacity observations made using Method 9 (40 CFR part 60, Appendix A-4) to demonstrate compliance with §60.672(b), (e) and (f).

(g) The owner or operator of any wet material processing operation that processes saturated and subsequently processes unsaturated materials, shall submit a report of this change within 30 days following such change. At the time of such change, this screening operation, bucket elevator, or belt conveyor becomes subject to the applicable opacity limit in §60.672(b) and the emission test requirements of §60.11.

(h) The subpart A requirement under §60.7(a)(1) for notification of the date construction or reconstruction commenced is waived for affected facilities under this subpart.

(i) A notification of the actual date of initial startup of each affected facility shall be submitted to the Administrator.

(1) For a combination of affected facilities in a production line that begin actual initial startup on the same day, a single notification of startup may be submitted by the owner or operator to the Administrator. The notification shall be postmarked within 15 days after such date and shall include a description of each affected facility, equipment manufacturer, and serial number of the equipment, if available.

(2) For portable aggregate processing plants, the notification of the actual date of initial startup shall include both the home office and the current address or location of the portable plant.

(j) The requirements of this section remain in force until and unless the Agency, in delegating enforcement authority to a State under section 111(c) of the Act, approves reporting requirements or an alternative means of compliance surveillance adopted by such States. In that event, affected facilities within the State will be relieved of the obligation to comply with the reporting requirements of this section, provided that they comply with requirements established by the State.

(k) Notifications and reports required under this subpart and under subpart A of this part to demonstrate compliance with this subpart need only be sent to the EPA Region or the State which has been delegated authority according to §60.4(b).

**SECTION D. Source Level Requirements****V. REPORTING REQUIREMENTS.**

No additional reporting requirements exist except as provided in other sections of this permit including Section B (State Only General Requirements).

**VI. WORK PRACTICE REQUIREMENTS.**

No additional work practice requirements exist except as provided in other sections of this permit including Section B (State Only General Requirements).

**VII. ADDITIONAL REQUIREMENTS.**

**# 010 [25 Pa. Code §127.441]**

**Operating permit terms and conditions.**

The following equipment is subject to 40 CFR Part 60 Subpart OOO - Standards of Performance for Nonmetallic Mineral Processing Plants:

Facility ID - Description

#003 - SECO 8x20 Vibrating Screen

#007 - Telsmith 8x24 Vibrating Screen

#008 - Telsmith 8x24 Vibrating Screen

#020 - Telsmith 8x24 Vibrating Screen

#011 - Telsmith 5x12 Wet Screen

#015 - Diester 7x16 Screen rated at 890 tph

#016 - Allis-Chalmers 1650 Crusher rated at 200 tph

#017 - Allis-Chalmers 6-51 Crusher rated at 200 tph

**SECTION D. Source Level Requirements**

Source ID: 201

Source Name: HAUL ROADS

Source Capacity/Throughput:

N/A

**I. RESTRICTIONS.**

No additional requirements exist except as provided in other sections of this permit including Section B (State Only General Requirements).

**II. TESTING REQUIREMENTS.**

No additional testing requirements exist except as provided in other sections of this permit including Section B (State Only General Requirements).

**III. MONITORING REQUIREMENTS.**

No additional monitoring requirements exist except as provided in other sections of this permit including Section B (State Only General Requirements).

**IV. RECORDKEEPING REQUIREMENTS.****# 001 [25 Pa. Code §127.441]****Operating permit terms and conditions.**

The Owner/Operator shall maintain a daily log of all roadway maintenance performed to prevent fugitive emissions. The log shall be maintained on-site for a minimum of five years and shall be made available to the Department upon request.

**V. REPORTING REQUIREMENTS.**

No additional reporting requirements exist except as provided in other sections of this permit including Section B (State Only General Requirements).

**VI. WORK PRACTICE REQUIREMENTS.****# 002 [25 Pa. Code §127.441]****Operating permit terms and conditions.**

- a) All in-plant roads shall be watered at least once per day during warm weather, at the start of each shift, if no precipitation has fallen within the previous twenty-four (24) hours, and as needed thereafter on a preventative basis such that visible fugitive emissions are controlled. Other methods of dust control may be used when weather conditions make the watering of unpaved roads hazardous.
- b) The owner or operator shall promptly remove earth or other material from paved roads onto which earth or other material has been transported by trucking or earth moving equipment, or other means.
- c) A set vehicle pattern shall be established and maintained for vehicles entering and existing the plant.
- d) The owner or operator shall post a sign limiting speeds to less than that 15 mph on all in-plant roads.
- e) The owner or operator shall post and enforce a requirement stating "All trucks entering or exiting the plant property shall be properly tarpaulin covered or the load shall be thoroughly wetted to prevent dust from leaving the bed during transportation if not equipped with a tarpaulin." Vehicles with a gross vehicle weight rating of less than 10,000 pounds shall be exempt from this condition.



## SECTION D. Source Level Requirements

### VII. ADDITIONAL REQUIREMENTS.

No additional requirements exist except as provided in other sections of this permit including Section B (State Only General Requirements).



**SECTION E. Source Group Restrictions.**



**SECTION F. Alternative Operation Requirements.**

No Alternative Operations exist for this State Only facility.



**SECTION G. Emission Restriction Summary.**

Source Id	Source Description
108	CRUSHING/SCREENING PLANT

Emission Limit	Pollutant
0.040 gr/DRY FT3	TSP

**Site Emission Restriction Summary**

Emission Limit	Pollutant
----------------	-----------

**SECTION H. Miscellaneous.**

Source 108 consists of the following equipment (Each piece of equipment that is not subject to Subpart OOO is noted with a triple asterisk (\*\*\*)):

- #001 Allis-Chalmers 4265 Gyratory Crusher\*\*\*
- #002 Hewlett Robbins 8x20 Vibrating Screen\*\*\*
- #003 SECO 8x20 Vibrating Screen
- #004 Telsmith 6614 Gyratory Crusher\*\*\*
- #005 Telsmith 5x12 Vibrating Screen\*\*\*\*
- #006 Allis-Chalmers 600 Crusher\*\*\*\*
- #007 Telsmith 8x24 Vibrating Screen
- #008 Telsmith 8x24 Vibrating Screen
- #020 Telsmith 8x24 Vibrating Screen
- #009 Allis-Chalmers 60" Gyratory Crusher\*\*\*
- #010 Allis-Chalmers 60" Gyratory Crusher\*\*\*
- #011 Telsmith 5x12 Wet Screen
- #015 Diester 7x16 Screen rated at 890 tph
- #016 Allis-Chambers 1650 Crusher rated at 200 tph
- #017 Allis-Chamber 6-51 Crusher rated at 200 tph

The facility consists of the following source not subject to additional requirements:

- One (1) 1,000 Gallon Diesel Fuel Storage Tank





\*\*\*\*\* End of Report \*\*\*\*\*

---